

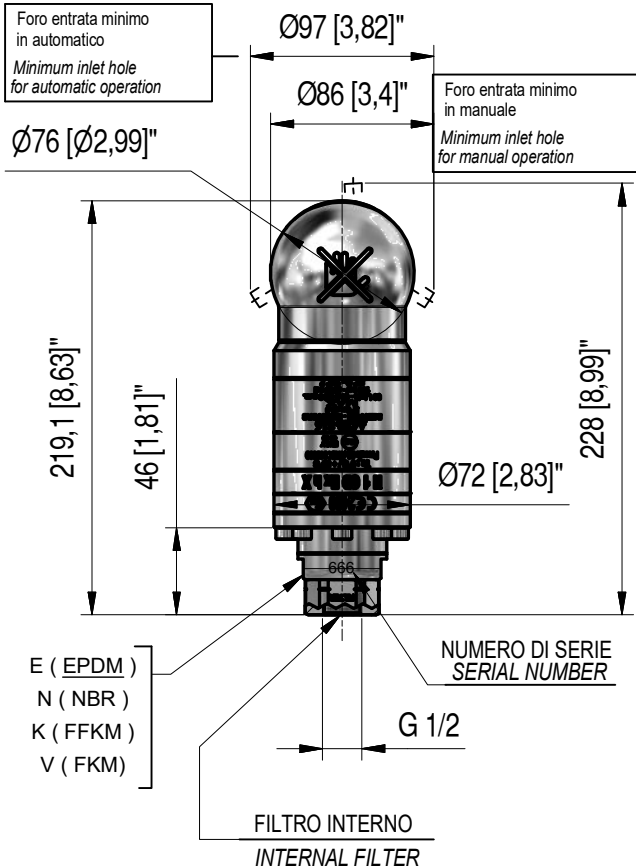

A42R-316 **CE**2460 **Ex**

II 1 G Ex h IIC T6...T4 Ga
II 1 D Ex h IIIC T85°C...T135°C Da

MANUALE ISTRUZIONI
INSTRUCTIONS BOOK



TESTINA AUTOMOVENTE

- Costruzione in acciaio INOX AISI 316.
 - Idonea per impiego settore alimentare.
 - Testina volumetrica , la velocità di rotazione è proporzionale alla portata in ingresso.
 - Lavaggio superfici interne di contenitori.
 - Portata ridotta, alta pressione, elevata forza di impatto.
 - Copertura orbitale degli interni.
 - Minimo ingombro radiale che ne permette l'introduzione in passaggi ridotti
 - Velocità di rotazione indipendente dalla temperatura dell'acqua.
 - Filtro in entrata.
- ATTENZIONE !**
- La Testina STANDARD è fornita di guarnizioni (DINAMICHE) in PTFE + O-Ring EPDM .
 - Lubrificare solo con:
Grasso al silicone teflonato
 - Per l'utilizzo di liquidi detergenti, additivi chimici ecc. non compatibili con le guarnizioni standard è indispensabile contattare il nostro UFFICIO TECNICO.
 - Le guarnizioni (STATICHE) sono in FKM (viton).
 - Tutti i materiali utilizzati per la costruzione sono approvati dalla NSF.

CLEANING HEAD

- Stainless steel construction.
- Suitable for utilization in food industry.
- This is a self-propelled tank cleaning head: when the flow rate increases, the head rotates faster.
- Cleaning of interior surfaces of tanks and drums.
- Reduced flow, high pressure, high cleaning impact.
- Orbital coverage of interior surfaces.
- Small spray turret that fits through reduced tank opening.
- Rotating speed independent from water temperature.
- Inlet filter

ATTENTION !

- The STANDARD Tank cleaning head is supplied with seals (DYNAMIC) in PTFE + O-Ring EPDM .
- Lubricate only with silicone-teflon grease
- For use with Detergent liquid, Chemical additives etc that are not compatible with the standard seals, it is essential to contact our TECHNICAL OFFICE for further information.
- The STATIC seals are in FKM (viton)
- Materials used for manufacturing have NSF approval.

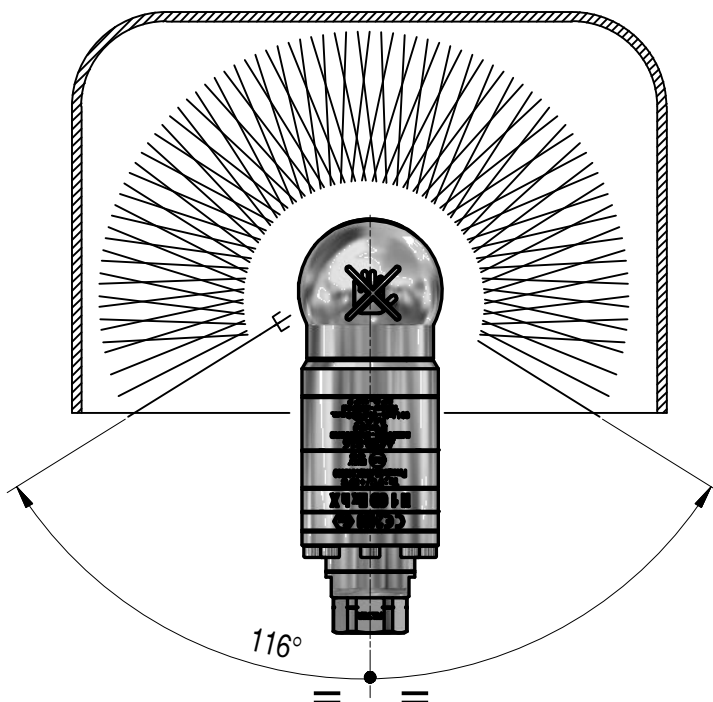

ATTENZIONE: NON UTILIZZARE L'APPARECCHIO PRIMA DI AVER LETTO QUESTO MANUALE DI ISTRUZIONE

CAUTION: DO NOT USE THE CLEANING HEAD BEFORE HAVING READ THE INSTRUCTION BOOK



EQUIPAGGIAMENTI
TECNICI
LAVAGGIO

TESTINE ROTANTI
TANK CLEANERS
MOD. A42R-316 (ATEX)



4

28

12.9428.16

Rev. 04
10/04/2020

A42R-316

CE2460

II 1 G Ex h IIC T6...T4 Ga

II 1 D Ex h IIIC T85°C...T135°C Da

MANUALE ISTRUZIONI

INSTRUCTIONS BOOK

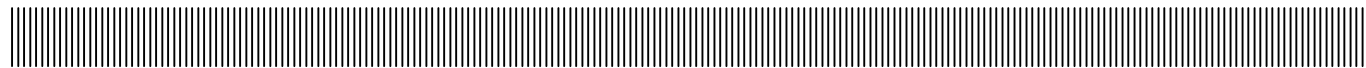

SPECIFICHE TECNICHE

TECHNICAL SPECIFICATIONS

- PRESSIONE NOMINALE <i>RATED PRESSURE</i>	40÷140 bar - 4÷14 MPa (580÷2000 psi)
- PRESSIONE CONSENTITA <i>PERMISSIBLE PRESSURE</i>	160 bar - 16 MPa (2300 psi)
- PORTATA / <i>FLOW RATE</i>	20-55 l/min (5.3 - 14.5 USGp.m.)
- TEMPERATURA MASSIMA ACQUA <i>MAX WORKING TEMPERATURE</i>	0-90°C (32-195~F)
- PESO / <i>WEIGHT</i>	4.6 kg (10.14 lb)
- FREQUENZA ROTAZIONE ASSE PRINCIPALE <i>MAIN AXIS ROTATING SPEED</i>	18-24 giri/min (RPM)
- ATTACCO ALIMENTAZIONE ACQUA <i>INLET CONNECTION SIZE</i>	1/2 Gas
- ATTACCO UGELLI (2 o 4) <i>NOZZLES CONNECTION (2 OR 4)</i>	1/8 NPT
- MATERIALI, TRATTAMENTI, LUBRIFICANTI CONFORMI A <i>MATERIALS, TREATMENTS, LUBRICANTS IN COMPLIANCE WITH</i>	NSF STANDARD 51

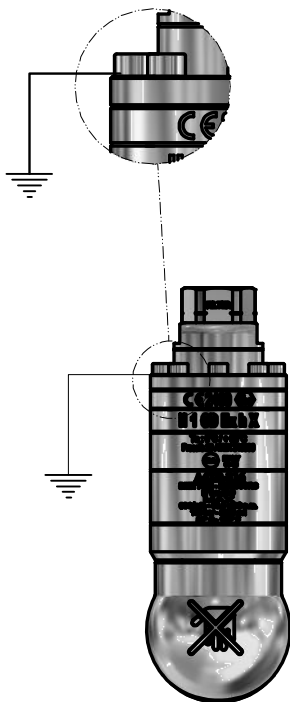

-D1-

TEMPO PER UN CICLO COMPLETO DI LAVAGGIO
(47 GIRI DELL'ASSE PRINCIPALE)

TIME FOR A COMPLETE CLEANING CYCLE
(47 MAIN AXIS REVOLUTION)

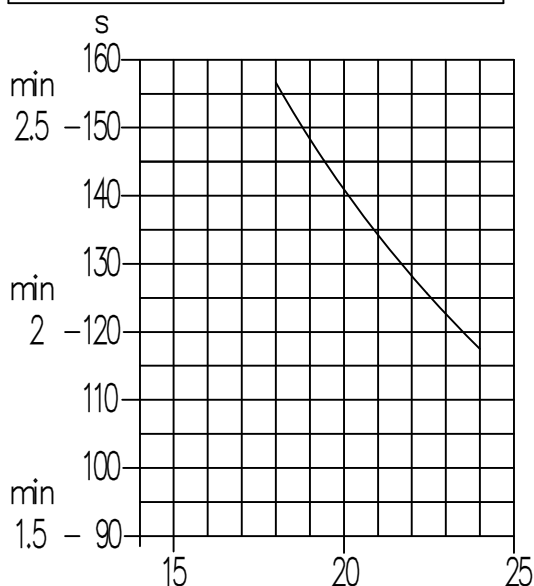

VELOCITA' DI ROTAZIONE giri/min
ROTATING SPEED RPM

TEMPO PER UN CICLO BREVE DI LAVAGGIO
(23,5 GIRI DELL'ASSE PRINCIPALE)

TIME FOR A SHORT CLEANING CYCLE
(23,5 MAIN AXIS REVOLUTION)

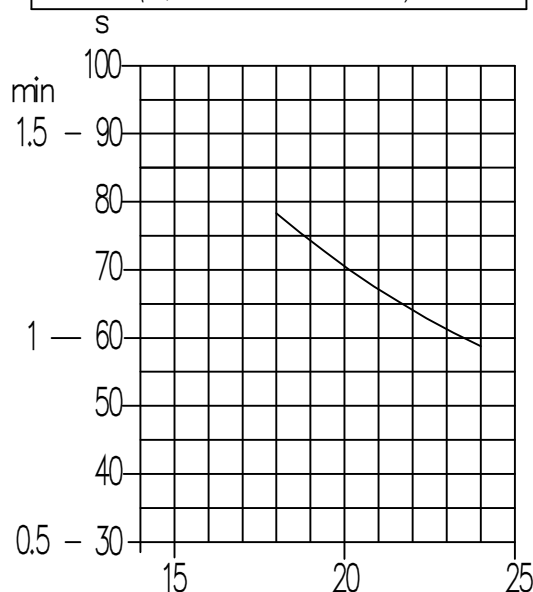

VELOCITA' DI ROTAZIONE giri/min
ROTATING SPEED RPM

-D2-



ATEX HYDROKINETIC ROTATING CLEANING HEADS SAFETY NOTE

SN01

Rev. 00

Date 22/04/2020

Pag. 1 of 10

DOCUMENT REVISION

REV.	DATE	MODIFICATION
00	22/04/2020	First issue

PREPARED BY	RGQ	Michele QUATTRONE	SIGNATURE
CHECKED BY	DUT	Fabio PEDRONI	SIGNATURE
APPROVED BY	AD	Alberto BENETTI	SIGNATURE



ATEX HYDROKINETIC ROTATING CLEANING HEADS SAFETY NOTE

SN01

Rev. 00

Date 22/04/2020

Pag. 2 of 10

INDEX

1.	INTRODUCTION	3
2.	DESCRIPTION OF THE PRODUCT	3
2.1	CLASSIFICATION & MARKING	3
2.2	FIELD OF APPLICATION	4
2.3	TERMS USED.....	5
3.	INSTRUCTIONS FOR USE.....	5
3.1	STORING, SHIPPING AND MOVING.....	5
3.2	INSTALLATION	5
3.2.1	WARNING	5
3.3	NOZZLE SELECTION.....	5
3.4	FILTERING OF LIQUID.....	6
3.4.1	CONNECTION & SETTING	6
3.5	USE & WORKING	6
3.5.1	WORKING & ADJUSTMENT	6
3.5.2	SUITABLE & NON-SUITABLE USE	7
3.5.3	DANGEROUS AREAS	7
3.5.4	DANGER & POSSIBLE RISKS.....	7
3.5.5	PPE (PERSONAL PROTECTIVE EQUIPMENT) & PROCEDURES TRAINING	8
3.6	SYSTEM PROCEDURES.....	9
3.6.1	TOOLS & MACHINERY.....	9
3.6.2	LOAD & UNLOAD.....	9
3.6.3	START & STOP	9
3.7	INSPECTION, ORDINARY & EXTRAORDINARY MAINTENANCE, SERVICE & CLEANING	9
3.7.1	PRECAUTIONS	9
3.7.2	ORDINARY MAINTENANCE AND CLEANING	9
3.7.3	EXTRAORDINARY MAINTENANCE AND REPAIR.....	10
3.7.4	INHIBITION AND RE-INSTALLATION OF THE HEAD	10
3.7.5	REPLACEMENT OF PARTS & SPARES.....	10
3.8	PREVENTION & REPRESSIVE ACTIONS (PRECAUTIONS)	10



ATEX HYDROKINETIC ROTATING CLEANING HEADS SAFETY NOTE

SN01

Rev. 00

Date 22/04/2020

Pag. 3 of 10

1. INTRODUCTION

PLEASE READ THE FOLLOWING INSTRUCTIONS CAREFULLY BEFORE INSTALLING ANY EC-MARKED PART (CLEANING HEAD), ACCORDING TO THE ATEX PARTS DIRECTIVE 2014/34/EU IN A POTENTIALLY EXPLOSIVE ATMOSPHERE AS DEFINED IN THE ATEX WORK ENVIRONMENT DIRECTIVE 99/92/EC. This manual must be brought to the attention of the personnel working with the head, and must be illustrated to the personnel qualified for maintenance and repair of the head. Any substantial modification to the head will not be allowed.

Any substantial modification must be authorized by P.A. S.p.A. (for a broader definition of substantial modification, please see maintenance manual).

2. DESCRIPTION OF THE PRODUCT

2.1 CLASSIFICATION & MARKING

The unequivocal identification of the equipment is to be verified by the data imprinted on the body and by the declaration of conformity attesting that the tool was subjected to a conformity test according to directive 2014/34/EU, annex VIII, requiring for a technical file to be sent to a Certification Body.

The marking of the cleaning head is:

CE 2460 Ex
II 1 G Ex h IIC T6...T4 Ga
II 1 D Ex h IIIC T85°C...T135°C Da
Ta: 0°C / +90°C

Presafe 20 ATEX 319809

where:

- Symbol 2460: DNV GL Presafe AS Certification Body
- Symbol CE Ex: in accordance with directive 2014/34/EU
- Group II: suitable on surface
- Category 1: suitable in zones 0 - 1 - 2 for gas and in zone 20 - 21 -22 for dust
- Substance type: G (gas) and D (dust)
- Specific type of protection: "Ex h" (construction safety)
- Group of gas/dust: IIC (gas) and IIIC (dust)
- Temperature Class/Max surface temperature: T6...T4 (gas) and T85°C...T135°C (dust) (see note 1)
- EPL: Ga (gas) and Da (dust)
- Ambient Temperature: 0 ÷ +90 °C
- Certificate Number: Presafe 20 ATEX 319809
- Additional marking on equipment: material of the Seals: E - N - K - V (see note 2)

The measures of prevention and protection described in this manual do not determine the level of safety required if the heads will not be used according to the provisional use, nor if they were not installed and subjected to maintenance according to the terms of use or appropriate requirements.



ATEX HYDROKINETIC ROTATING CLEANING HEADS SAFETY NOTE

SN01

Rev. 00

Date 22/04/2020

Pag. 4 of 10

2.2 FIELD OF APPLICATION

The head is designed to be used with water up to 90 °C, with addition of mild detergents or disinfectants. In case of use with special or even flammable liquids (different viscosity, chemical harshness or other), please contact our technical department. The head shall be used within pressure, temperature and RPM speed limits reported in the official documents, such as declaration of conformity, certificate of assembly and technical data reported on the instruction manual.

The cleaning liquid shall have an ignition temperature of minimum 50 K over the maximum exterior temperature of the appliance's surface where the cleaning liquid is utilized.

The ambient temperature when the appliance is working shall range between 0 ÷ +90 °C. For a different use, please contact the manufacturer for a customized study.

Only when it's used according to the prescriptions included in this manual and in correctly tackling residual risks raising from its use, does this head assure a level of protection high enough as to not generate potential sources of priming, when installed in a potentially explosive environment.

The appliance in question grants that potential sources of priming are not activated in normal functioning and even in case of foreseeable and rare failure or malfunction.

Breakage or failure to the appliance can happen. In that case, it is necessary to check the causes of failure. When these are traced down to the appliance, they must be removed.

Note 1: the appliance reaches a maximum surface temperature according to the temperature of the fluid pumped in. The temperature class must take into account the safety factor 0,8 aimed for appliances of class 1, see table below.

FLUID TEMPERATURE °C	TEMPERATURE CLASS (GAS)	MAX EXTERIOR SURFACE TEMPERATURE (DUSTS)
0 to ≤ 68	T6	T85 °C
> 68 to ≤ 80	T5	T100 °C
> 80 to ≤ 90	T4	T135 °C

Note 2: the cleaning liquid is to be chemically compatible with the seals that have been assembled by the manufacturer of the appliance. The marking will identify the material of the seals, as per the following chart:

MARKING ON THE EQUIPMENT	MATERIAL OF THE SEALS
E	EPDM
N	HNBR
K	FFKM
V	FKM

Compatibility (category - zoning) between the head and the environment must be established by the user according to exact and specific considerations Directive 99/92/EC.

It is not allowed to use the heads in potentially explosive atmospheres in underground and mining areas, EPL Ma and Mb (group I category M1 and M2).



ATEX HYDROKINETIC ROTATING CLEANING HEADS SAFETY NOTE

SN01

Rev. 00

Date 22/04/2020

Pag. 5 of 10

2.3 TERMS USED

Qualified/Specialised Technician: personnel who was trained for installation, adjustment, maintenance, repair. It is required that the technician shall be trained and allowed to perform such tasks, and to have specific knowledge not only of the tool and the risks stemming from its use, but also the possible risks of the appliance in question.

Temperature Class (T): it is the maximum superficial temperature of the appliance (taking into account also the safety coefficient as reported in UNI CEI EN ISO 80079-36:2016. It also corresponds to the max. surface temperature of the head.

3. INSTRUCTIONS FOR USE

3.1 STORING, SHIPPING AND MOVING

The heads are supplied with adequate packaging. The unloading and moving of the tools shall be carried out by trained personnel, who is also responsible for checking that the order and the freight match.

It is necessary to carefully move the head to avoid shock impacts, and therefore, possible deformations and cracks which could successively determine leaking of the product contained through the attachment points of the head a/w possible trigger source (sparks, adiabatic compression, etc.).

Localities of Warehouse storage, conservation, transport and movement of the heads must guarantee that they are not subject to shock impacts, tumbles, deterioration and other damaging which could compromise the function of the head.

Any eventual damage must be immediately communicated to P.A. S.p.A. for assessment.

3.2 INSTALLATION

3.2.1 WARNING

Each installation or reinstallation must be performed by qualified personnel, duly trained and informed on the related risks, even concerning the instructions of this document.

When using the utensils do not apply excessive force rotation on the connections in the presence of a potential explosive atmosphere.

The use of utensils in zone 0 and 20 is not permitted. The use of utensils in zone 1/21 and 2/22 is allowed with particular instructions under the directive UNI CEI EN ISO 80079-36:2016 which has to be known by the operator.

Installation errors can provoke deformation or structural collapse of the pipe connection, also a loss of fluid in the ambient.

Installation errors can compromise the regular movement with effective possibility of sparking.

3.3 NOZZLE SELECTION

The nozzles, in numbers of 2 or 4 of high pressure washing type with straight jet, must be appropriate to the flow & pressure in which they intend to operate (see nozzles chart) bearing in mind that the pressure spec. to consider in the choice is the one achieved by subtracting from the pressure value in the pump, the value of the pressure loss determined by the delivery line and head. This last value can be obtained from the diagram D3 of this manual. The nozzles must be made of material compatible with the directive 2014/34/EU and category 1.



ATEX HYDROKINETIC ROTATING CLEANING HEADS SAFETY NOTE

SN01

Rev. 00

Date 22/04/2020

Pag. 6 of 10

3.4 FILTERING OF LIQUID

The fluid sent from the system to the head has to be filtered in order to prevent particles to slip through causing malfunction and therefore frequent maintenance interventions. The recommended sealed filter has to be at least 300 microns. The head is fitted with a filter of 550 microns which only has a safety function; we recommend to clean it every 100/300 hours of functioning. In case of filter breakage, dismount the head, clean it from any eventual internal residue and fit a new filter.

3.4.1 CONNECTION & SETTING

The head must be connected to a pressure application, usually fed by piston pumps, pressure washers and similar; in order to prevent possible damage to persons and things, where such an application must be equipped with all safety parts and control (like safety valves, regulating etc.) foreseen by the directives in force. Use a resistant and adequate sized tube for the connection, possibly avoiding narrow necks and abrupt direction variations to restrain the pressure loss.

The head must be anchored firmly at the Tank opening or by an appropriate support. This type of head must be held and fed by a fixed pipe that prevents any swinging.

The connecting tube to the head must be of such to help the fluid flow without any excessive pressure drop.

The assembler is compelled also to carry out the inspection of all the connection links.

The apparatus must be installed by the following procedure:

- Assure that there is no obstacle placed between head and attachment; place a suitable gasket that assures a seal age conform and a protection grade minimum IP54 for Gas and IP6X for powders.
- Insert the connection tubes (entry and exit) following a good technique and using acknowledged components, adopting the foreseen clamping instructions.
- During the connection of the tubes, make an electrical earth link-up with a minimum cable size 4mm observing the prescribed terms for equipotential connections.
- Inspection after installation, to be carried out by the assembler or end user, in particular the perfect coupling of usage at the various openings (keep to the limit levels of emission rated in the zoning phase).

3.5 USE & WORKING

3.5.1 WORKING & ADJUSTMENT

The rotation of the head is achieved using the same fluid under pressure bound for washing, by means of a hydrokinetic group set up by a turbine operated by three injectors and a epicycloid reducer; this system gives a raised torque on exit. We therefore recommend to fit a nozzle protection kit code 25.4822.00 in order to protect the nozzles from matter. The rotation frequency can be regulated, within the indicated values of the Technical specifications, by altering the orifice diameter of the three internal injectors (pos.22 exploded view) of the hydrokinetic group which is always directly proportional of the flow rate as seen from the D3 diagram of this manual.

Pressure changes (at constant flow rate) or water temperature do not modify the rotation frequency value. A complete washing cycle is carried out after 58 revs of the main axis, considering that a complete washing cycle is over once the jets have covered an ideal sphere and have returned to the starting point. The time for a complete cycle, directly proportional to rotation frequency, can be obtained from diagram D2 of this manual. For a perfect washing we recommend at least 3 complete cycles.

The procedures to observe during function concern the process levels and correct running.



ATEX HYDROKINETIC ROTATING CLEANING HEADS SAFETY NOTE

SN01

Rev. 00

Date 22/04/2020

Pag. 7 of 10

3.5.2 SUITABLE & NON-SUITABLE USE

Overall utilization: The head can work solely by a continuous flow which fills constantly the body, minus impurities and air bubbles. The rotation of the head forms a strong trigger source if this should occur with an empty head. However, the head is operated solely by the water flow and the rotation starts only by a significant minimum pressure function. If there is a lack of the water flow, the internal members stop. A 3 bar minimum pressure from the mains guarantees constantly the filling of the head and therefore prevents eventual void rotations. Install a gauge to verify the mains pressure.

The cleaning liquid should have an ignition temperature of minimum 50K over the maximum exterior temperature of the appliance's surface where the cleaning liquid is utilized. (T=200 °C).

It is forbidden to make substantial modifications to the head (replacement of parts not recognized by P.A. S.p.A. or assembly variations). In the other cases of ordinary & extraordinary maintenance and repairs, refer to the maintenance manual.

In no case is it foreseeable to guarantee the protection from trigger sources for superior strains other than those maximum permitted (PS – TS –velocity) considered in the planning stage, in view of the safety measures adopted.

The Company P.A. S.p.A. declines all responsibility for damage to persons, animals or things derived by an improper use of the apparatus a/o the non observance of the dispositions contained in the present manual.

3.5.3 DANGEROUS AREAS

Particular attention has to be reserved to any area potentially explosive around the head and also from the inside. Do not open the head in areas potentially explosive and during working. Before opening the head, disconnect it from the machine and bring it to a safe area.

It is severely forbidden to operate on the tightening components and on the apparatus connections whilst running and in any case each time it is predictable that the area may contain a potentially explosive ambient.

3.5.4 DANGER & POSSIBLE RISKS

Hot surfaces

The heads always present the danger of hot surfaces due to the maximum temperature of 90°C: always check that the internal fluids and external areas cannot trigger off at such a temperature. The surface temperature must not be higher than 80% of the minimum temperature ignition of the Gas measured in °C.

Naked flames and hot gas

Naked flames and hot gas are forbidden around the head.

Mechanical sparks

Sparks have to be excluded during a normal function even if they can occur in case of foreseen and rare dysfunctions; they can be caused by friction, knocks or abrasion, hammering.

Ultrasounds (acoustic danger)

Tank measurement is forbidden when the head is in function.



ATEX HYDROKINETIC ROTATING CLEANING HEADS SAFETY NOTE

SN01

Rev. 00

Date 22/04/2020

Pag. 8 of 10

Electric currents and protection against cathode corrosion. Static electricity

Earth connect all the wires which could dangerously charge through certain connection points.

The installer is responsible for checking that there are no insulated metal parts.

The User must regularly check the effectiveness of the ground connection.

Adiabatic compression and shock waves

The process that can cause adiabatic compression or shock waves are not tolerated. Verify the normal function of the wash fluid in the adduction systems.

Exothermic/Endothermic reactions, including self-ignition of powders

Wash fluids with endothermic characteristics or reactive with water and impurities are forbidden.

Excessive vibrations and stress

Stress derived from vibrations, especially transmitted by the tube connections and other connected apparatus are forbidden; where such conditions cannot be guaranteed, appropriate measures must be taken to reduce to the minimum such phenomena.

Back pressure

An elevated back pressure to the nozzles acts negatively on the head compromising the set calibration. The nozzles must be exempt from back pressure: They must not be blocked and no flow from the nozzles towards the inside of the head is permitted.

Ambient risks

Ambient conditions different than those specified can cause a danger source.

They can cause dangerous service conditions (with relation to the processed fluids) an abrupt movement, humidity effects, ambient temperatures and pressure changes, chemical agents, corrosion.

The working process in the installations must be carried out in such a manner to be not determined by a dangerous influence.

Refrain from the functioning of the head in case of evident irregularities. The rupture of some components provoke a non hydrokinetic function of the head.

3.5.5 PPE (PERSONAL PROTECTIVE EQUIPMENT) & PROCEDURES TRAINING

The choice of PPE (Personal protective equipment) is user's responsibility according to the local safety regulation, predicting the following residuary risks:

- Hot surface temperatures
- Electrostatic charges
- Inflammable liquids, noxious substances, etc
- Others in relation to type of use

The use of the head must foresee a precise training formation.

It is necessary to pertain to the application of the local safety regulation.



ATEX HYDROKINETIC ROTATING CLEANING HEADS SAFETY NOTE

SN01

Rev. 00

Date 22/04/2020

Pag. 9 of 10

3.6 SYSTEM PROCEDURES

3.6.1 TOOLS & MACHINERY

The safety of the system is also in function with control devices (conform with Directive 2014/34/EU) which must be absolutely independent from the head.

3.6.2 LOAD & UNLOAD

Adequate means are foreseen for the draining and leakage in order to consent the cleaning operations, inspection and maintenance in absolute safety conditions.

3.6.3 START & STOP

In case of doubt and an irregular function, stop the productive process, do not make brief repairs and ask qualified personnel.

3.7 INSPECTION, ORDINARY & EXTRAORDINARY MAINTENANCE, SERVICE & CLEANING

3.7.1 PRECAUTIONS

Before proceeding to the periodic procedures of inspection, maintenance, repairs & cleaning it is necessary to discharge the internal pressure, through a duct converged in a safe area, to avoid damage to persons or things and to verify the occurred discharge phase by means of control devices (pressure gauges).

It is always necessary to verify the non-existence of potential explosive atmospheres and the impossibility to trigger off.

The user must certify that the operator is opportunely instructed to carry out all the safety procedures & hygiene in the work areas according to the protocol in order to avoid any eventual risks deriving from the operations mentioned above.

3.7.2 ORDINARY MAINTENANCE AND CLEANING

After a normal daily usage, wash the inside of the head with clean water without any additives. Carry out an internal check after 100 hours and check the conditions of the internal parts (gears, bearings, dynamic seals). The incorrect choice of the O-ring material (dynamic seals) can cause an irregular function and a rapid deterioration of these parts. In presence of dimensional alterations (swelling) of the dynamic seals (OR+PTFE), control the compatibility of the O-rings with the liquid used; if they result non-compatible, contact our Technical Department.

The cleaning stages are to be carried out regularly in view of the function and compulsory in the presence of matter a/o explosive powders on the head and nozzles (independently from the settled thickness)

For internal and external cleaning, it is necessary to use non corrosive products or solutions, suitable to remove the work residue, and that do not damage the O-ring surfaces and internal gears. For the cleaning operations do not use aggressive chemical detergents a/o mechanical systems that can cut or deform the head.



ATEX HYDROKINETIC ROTATING CLEANING HEADS SAFETY NOTE

SN01

Rev. 00

Date 22/04/2020

Pag. 10 of 10

3.7.3 EXTRAORDINARY MAINTENANCE AND REPAIR

Please check the internal parts every 300 / 400 hours of work in order to verify any premature wear of the parts. Replacement of the dynamic seals is recommended:

- A42R-316: pos. 23 and 32
- A42R-316-360°: pos. 3 and 16
- MI42-316: pos. 21 and 36
- A80RA: pos. 5 and 19
- MI63A: pos. 3 and 23

Verify that the slide surfaces of the seals are in good conditions: replace the parts if worn out. Check also bearings, bushings and gears: replace if damaged.

Use only original "PA" spare parts.

Lubricate only with silicone grease (14.6552.00) and do not use mineral grease or oil otherwise internal parts will be subject to rupture.

If exposed to freezing temperatures, make sure that the cleaning head is completely emptied after use in order to prevent the freeze.

For all details regarding assembly and disassembly of the cleaning head, please see the Maintenance Manual.

3.7.4 INHIBITION AND RE-INSTALLATION OF THE HEAD

For a working order inspection of the apparatus or for maintenance/replacement, the removal of the head from the application is permitted only when the apparatus is not under pressure and in the absence of a potential explosive atmosphere.

Before reusing or reutilizing the head after washes, general maintenance or any other necessary operation, follow the warnings as seen on paragraph 3.1.1. of this safety note

After reinstalling the device, and before placing the equipment under pressure, verify the correct tightness between the connections and apparatus and its efficiency.

3.7.5 REPLACEMENT OF PARTS & SPARES

It is necessary to replace the head and/or its components when, upon the user's discretion, the safety functions are not guaranteed during working. The replacement of head parts with others not identical to those original cannot guarantee the design conditions established by P.A. S.p.A.

3.8 PREVENTION & REPRESSIVE ACTIONS (PRECAUTIONS)

The user must use suitable measures to eliminate a/o reduce potential explosive atmospheres externally to the head applying the Directive 99/92/EC.

The user must pertain to what established in order to:

- Avoid, however possible, the formation of explosive atmospheres (concentration-classification limits of the areas);
- Choose qualified control systems;
- Avoid the creation of lively trigger sources (prevention).

25.5600.20 A42 R -Ai316 Test.semov., 20 l/min Atex
 25.5600.30 A42 R -Ai316 Test.semov., 30 l/m.Atex2460

25.5600.40 A42 R -Ai316 Test.semov.40 l/m.Atex2460

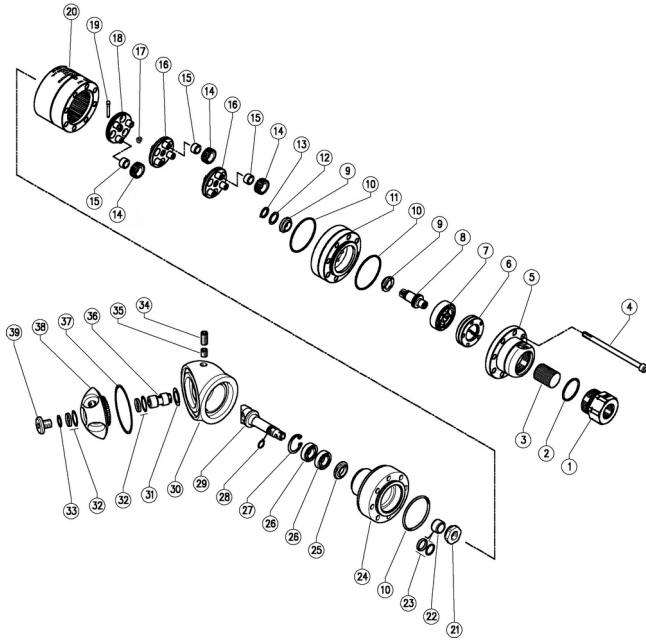

Pos.	Codice	Descrizione	Q.tà	K1	K2	K3	K4	
1	80.0813.60R	Raccordo entrata Ai316	1					3
2	10.3077.19R	An. or 1,78 x 28,30mm NSF	1					5
3	80.0820.63R	Rete, 21,5x26,5 mm Ai316 inox	1					10
4	16.1909.00R	Vite DIN912 M6x90 mm inox	8					10
5	80.0803.60R	Corpo entrata inox	1					1
6	80.0836.60R	Iniettore 3 fori D.2,8mm Ai316 (1)	1					1
6	80.0837.60R	Iniettore 4 fori D.3,4mm Ai316 (2)	1					1
6	80.0801.60R	Iniettore 6 fori D.3,4mm (3)	1					1
7	80.0512.84R	Turbina plast.	1					3
8	80.0834.21R	Albero turbina inox	1					1
9	80.0548.84R	Boccola	2					3
10	10.3034.19R	An.O-Ring, 1,5x45 mm Vi 70-Nsf	3					10
11	80.0811.60R	Flangia entrata Ai316	1					1
12	80.0814.53R	Anello rasamento	1					5
13	10.0999.60R	Anello elas.12mm inox	1					10
14	80.0821.60R	Satellite z:24 Ai316	9					3
15	80.0822.84R	Boccola Di.8x12 mm	9					3
16	80.0833.21R	Portasatelliti intermedio completo	2					1
17	80.0213.84R	Perno rasamento plast.	1					10
18	80.0832.21R	Portasatelliti completo+sp+rasam	1					1
19	80.0808.60R	Spina 3x24,5mm Ai316	1					3
20	80.0809.60R	Corpo 3 stadi Ai316	1					1
21	80.0807.60R	Ghiera M12x1 mm Ai316	1					1
22	80.0816.60R	Boccola p/tenute nich.Ai316	1					5
23	10.2031.19R	Guarn. stelo 16 mm +OR	2					5
24	80.0851.60R	Pignone fisso z.45 inox Ai316	1					1
25	80.0852.60R	An. rasamento inox Ai316	1					3
26	11.4412.98R	Cuscinetto 12x28x8 mm - 2RS1 inox	2					3
27	10.1011.60R	Anello elas. I D 28mm inox	1					10
28	10.3019.19R	O-Ring, 1,5x9,0 mm Vi 70-Nsf	1					5
29	80.0854.60R	Perno inox Ai316	1					1
30	80.0853.60R	Calotta sferica Ai 316	1					1
31	80.0860.60R	An. rasamento 15,4x23x0,3mm inox Ai316	1					3
32	10.2031.16R	Guarn. stelo 15 mm +O-ring	2					5
33	80.0859.60R	Anello rasamento Ai316	1					3
34	16.2225.60R	Grano DIN913 M8x16 mm Ai316	1					10
35	16.2218.60R	Grano M8x8 mm inox Ai316 Uni 5929	1					10
36	80.0855.60R	Perno inox Ai 316	1					1
37	10.3270.19R	An.O-Ring, 3,53x59,92 mm Vi 70-Nsf	1					10
38	80.0861.21R	Portaug.sfer.+ingr.z.47 ino.Ai316	1					1
39	80.0858.60R	Perno M10 inox Ai316	1					1

(1) 25.5600.20 (2) 25.5600.30 (3) 25.5600.40

25.5600.20 A42-R -Ai316 Tank clean.s/prop.20
 25.5600.30 A42-R -Ai316 Tank clean.,s/prop., 30

25.5600.40 A42-R -Ai316 Tank clean.,s/prop.40

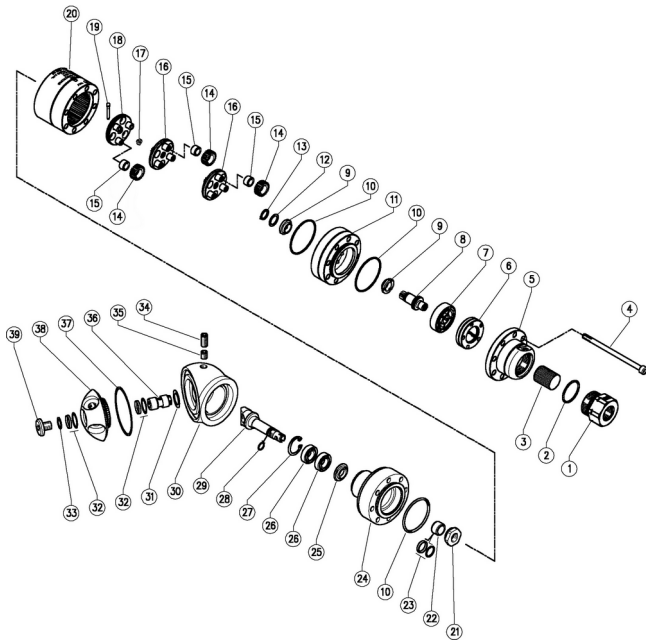

Pos.	P/N	Description	Q.ty	K1	K2	K3	K4	
1	80.0813.60R	Inlet coupl., 1/2Bsp F Sst.	1					3
2	10.3077.19R	O-Ring, 1,78x28,3 mm Vi 70-Nsf	1					5
3	80.0820.63R	Net, 21,5x26,5 mm Ai316 Sst.	1					10
4	16.1909.00R	Screw, DIN912 M6x90 mm Sst.	8					10
5	80.0803.60R	Inlet housing, Sst.	1					1
6	80.0836.60R	Ring injector, 3x2,8 mm Sst. Ai316 (1)	1					1
6	80.0837.60R	Ring injector, 4x3,4 mm Sst. Ai316 (2)	1					1
6	80.0801.60R	Ring injector, 6x3,4 mm Sst. (3)	1					1
7	80.0512.84R	Turbine, plast.	1					3
8	80.0834.21R	Gearred shaft, Sst.	1					1
9	80.0548.84R	Bushing ring	2					3
10	10.3034.19R	O-Ring, 1,5x45 mm Vi 70-Nsf	3					10
11	80.0811.60R	Sst. inlet flange	1					1
12	80.0814.53R	Shim ring, Sst.	1					5
13	10.0999.60R	Snap ring, E 12 Sst.	1					10
14	80.0821.60R	Planetary gear, z.24 Ai316	9					3
15	80.0822.84R	Bushing, . 8x12mm	9					3
16	80.0833.21R	Plan. gear holder+3 pins+gear, Sst.	2					1
17	80.0213.84R	Shim pin, plast.	1					10
18	80.0832.21R	Plan. gear holder+3 pins, Sst.+1 pin	1					1
19	80.0808.60R	Parallel pin, 3x24,5mm Ai316	1					3
20	80.0809.60R	Ring gear z.60, 3-stage cleaner, sst.	1					1
21	80.0807.60R	Ring nut M12x1 mm Ai316 sst	1					1
22	80.0816.60R	Seal holding pin, Sst.	1					5
23	10.2031.19R	Stem seal, 16x21x2,2 mm +O-ring	2					5
24	80.0851.60R	Fixed pinion, z.45 Sst. Ai316	1					1
25	80.0852.60R	Shim ring, Ai 316 Sst.	1					3
26	11.4412.98R	Ball-bearing, 12x28x8 mm - 2RS1 Sst.	2					3
27	10.1011.60R	Snap ring, I D 28 Sst.	1					10
28	10.3019.19R	O-Ring, 1,5x9,0 mm Vi 70-Nsf	1					5
29	80.0854.60R	Pin, Ai 316 Sst.	1					1
30	80.0853.60R	Spherical cap -A42R Ai 316.	1					1
31	80.0860.60R	Shim ring, 15,4x23x0,3mm Ai316 Sst.	1					3
32	10.2031.16R	Stem seal, 15 mm +O-ring	2					5
33	80.0859.60R	Shim ring, Sst. Ai316	1					3
34	16.2225.60R	Set screw, DIN913 M8x16 mm Sst.Ai316	1					10
35	16.2218.60R	Set screw, M8x8 mm Ai316 Sst. Uni 5929	1					10
36	80.0855.60R	Sst Ai 316 shaft	1					1
37	10.3270.19R	O-Ring, 3,53x59,92 mm Vi 70-Nsf	1					10
38	80.0861.21R	Spher.nzl hold,+gear z.47,Sst Ai316	1					1
39	80.0858.60R	Pin, M10 - Ai 316 Sst.	1					1

(1) 25.5600.20 (2) 25.5600.30 (3) 25.5600.40



P.A. S.p.A.
Via Milano, 13
42048 Rubiera, Reggio Emilia - Italy
Tel +39.0522.623611
Fax +39.0522.629600
info@pa-etl.it

www.pa-etl.it



COMPANY WITH QUALITY MANAGEMENT
SYSTEM CERTIFIED BY DNV
= ISO 9001 =